



Colt-Caloris

Water Source Heat Pump System

Climate Control



Approved for Enhanced
Capital Allowance

Positive Thinking

WHY IS COLT-CALORIS UNIQUE?

Colt-Caloris **patent EP 02 017 103.9** encompasses a wide range of features that sets it apart from the competition. Its design makes it highly efficient and environmentally friendly.

Colt has utilised over 70 years experience of solving climate control problems, to take a fresh approach to the challenges associated with air conditioning. Investigations have resulted in advanced, safer and 'greener' performing systems.



The Colt-Caloris system has been approved for Enhanced Capital Allowance



The Colt-Caloris system
combines the advantages of a
VRF system, with a safe and
flexible water based system



BENEFITS

Colt-Caloris is an ideal alternative to both conventional air conditioning and reverse cycle heat pump systems and includes benefits such as;

Energy Efficient - ECA Compliant

Low Noise levels (NR 28 - 35)

Flexibility for future expansion

**Individual control for heating
and cooling**

Extremely high unit COP, up to 7

**Neutral temperature of water loop
(between 15°C and 30°C)**

Uninsulated plastic piping

Slimline unit, only 247mm high

Vertical Wall Unit, only 480mm high

**System allows unlimited number of
units to be installed**

Maintenance free horizontal compressor

Features & Benefits

Colt-Caloris has many advantages over conventional air conditioning systems, including:

Independent local climate control

Very high efficiency and low running costs

Extremely cost effective

Utilises the building's thermal mass for energy storage, in order to re-use for heating or cooling

No Freon piping required

No insulation required for the pipework

Decentralised configuration means that the system can be easily modified to suit future alterations to the building.

it s time for change

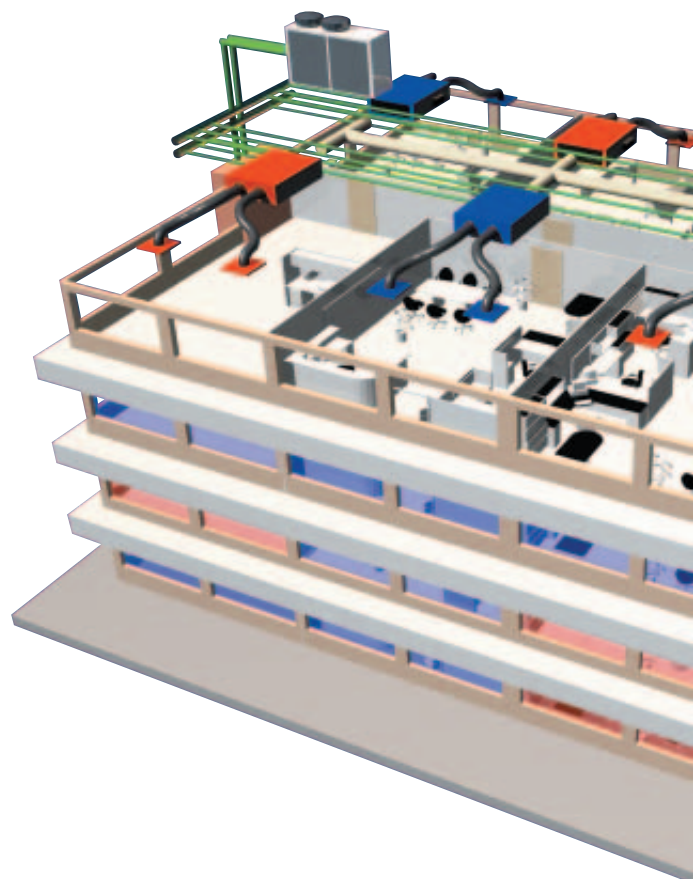

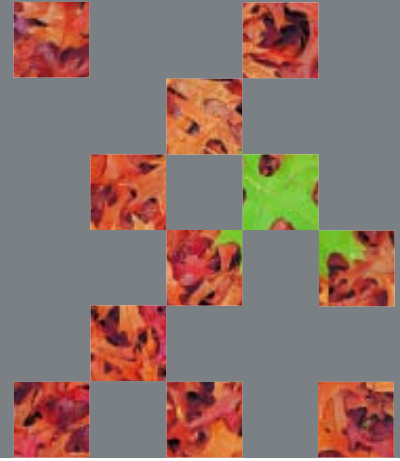

A new concept in air conditioning

FEATURES AND BENEFITS

Energy Savings & The Environment

Colt-Caloris has an extremely high COP, with room units ranging from 4 to 6 depending on the ambient temperature. A COP of 7 has even been achieved in favourable conditions. The overall system performance is approximately 4.3.

No other refrigerant based air conditioning system of equivalent capacity, contains a lesser charge of refrigerant, thus reducing its potential environmental impact.

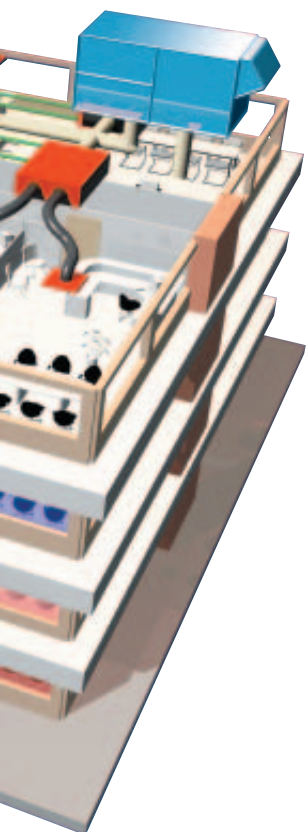

Low Noise Levels

All local Colt-Caloris units incorporate a small refrigerant compressor which, of course, generates some noise. By implementing strategically placed anti-vibration mounts, cradle supports and attenuation, Colt have been able to produce the quietest running units on the market.

All sizes have been independently tested and verified by Eurovent Certified laboratories.

Decentralised Individual Control

Everybody has their own personal comfort level. The Colt-Caloris system allows every local unit to operate at a temperature chosen by the user, irrespective of the location of the units.

Colt-Caloris affords freedom to heat and cool at the same time without modifications to the standard system.

Total Heat Recovery

All units are connected to the same water loop, mutually exchanging heat.

Colt-Caloris units achieve an extremely high recovery of thermal energy, irrespective of their position on the water loop.

When embedding the pipework into the concrete structure of the building, thermal capabilities will be further increased.

Unit Design

At just 247mm high, the horizontal units are the slimmest on the market and are designed to easily fit within most ceiling voids. The vertical units are just 480mm high, allowing for easy installation underneath a window.

Pipework

Unlike alternative systems, there is no limit to the pipework length in the Colt-Caloris. The system uses high quality, low cost, polyethylene piping unlike refrigerant systems which require insulated Freon pipework.

Colt-Caloris pipework is uninsulated: indeed, the system actually performs better without insulation. Utilising just two water pipes significantly reduces space requirements and installation time.

The length of the piping is irrelevant, 100m or 1000m, just 20 units to the system or 2000, Colt-Caloris is completely flexible.

Reliability

If in the unlikely event of a single unit failing, the other units will not be affected and the system will remain fully operational.

Introduction

SO, WHAT IS THE COLT-CALORIS SYSTEM?

Colt-Caloris consists of a series of heat pumps fitted within ceiling voids and a central external heat pump, which are connected by a neutral water loop. This water source heat pump system eliminates the requirements for refrigerant to be piped around the building.

Fresh or recirculated air is filtered, chilled or heated as necessary, and supplied through spigots, ducting and ceiling grilles in the internal space by the localised room units. The system is suitable for heating and cooling, offering individual or zone control.

Colt-Caloris has been designed with simplicity of installation in mind and since it emits low noise, it is particularly suitable for hotels, hospitals, schools and offices.

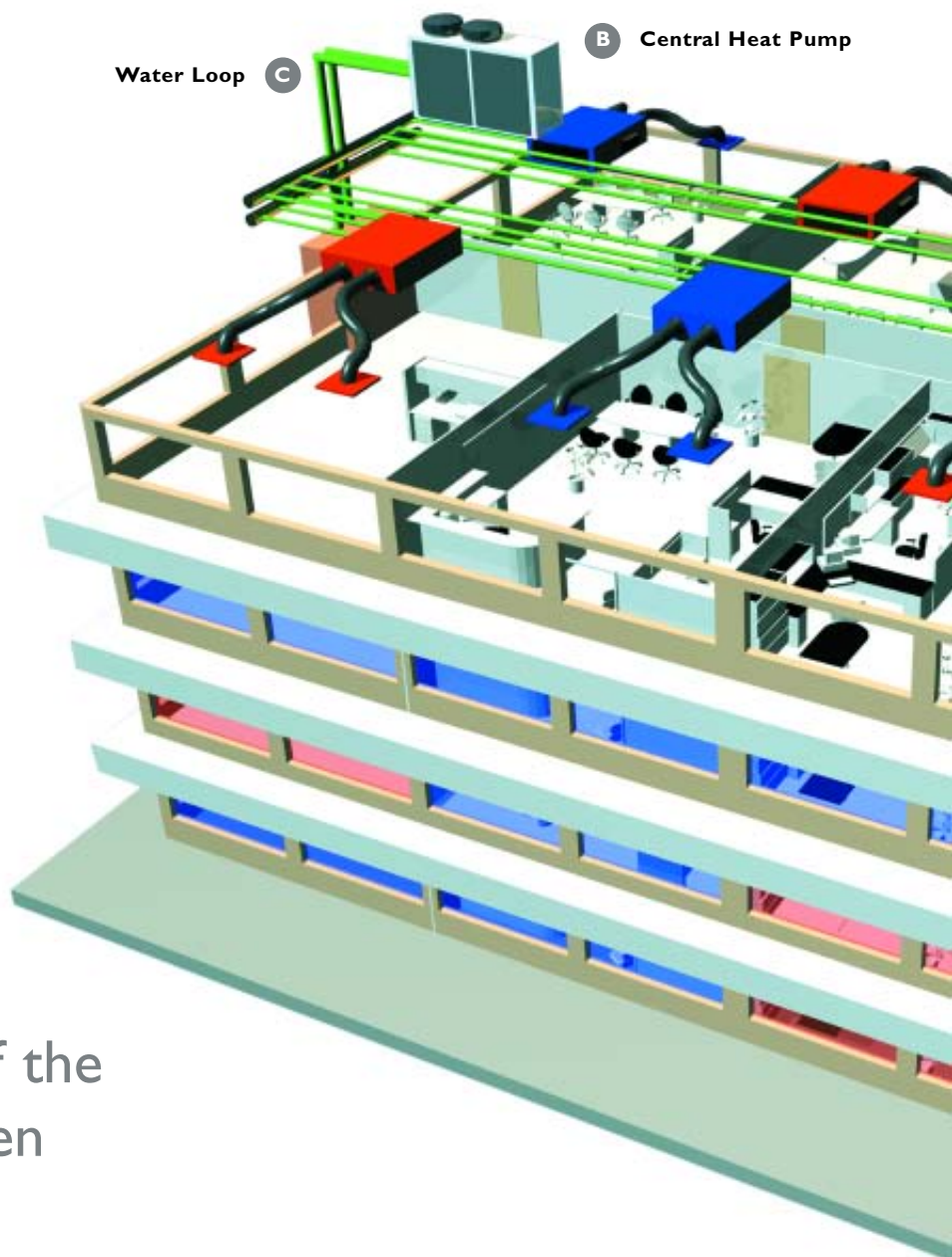

The temperature of the
water loop is between
15°C and 30°C



The Colt-Caloris is ideally suited for hotels, hospitals, schools and offices

A Local Heat Pump



- A Colt-Caloris Local Heat Pump**
An individual local heat pump within each room that converts the energy in the water to energy in the air
- B Central Heat Pump**
A central external heat pump that converts the energy in the air to energy in the water
- C Water Loop**
Uninsulated plastic piping to facilitate a balanced flow of water to all local heat pumps at an average of 25 °C

HOW DOES IT OPERATE?

Colt-Caloris is based solely on heat pump technology. A central heat pump is installed in a suitable location and local units are installed within the ceiling voids of the rooms. Each local unit also contains a heat pump.

The transportation of energy takes place by using water which is at approximately the same temperature as the rooms within the building. The local reverse cycle units use this neutral water to either warm up or cool down the air already circulating within the rooms.

Superfluous energy is recycled to the water. In order for this to work efficiently, the water loop should be integrated within the concrete floors of the building, to make use of the building's thermal mass. However, the pipe work can also be installed traditionally, within the ceiling void whilst still maintaining an excellent efficiency rating.

The central heat pump is charged to maintain the neutral temperature on the water loop.

For approximately 85% of the year, the water loop is expected to remain at this neutral temperature, requiring no external energy from the central heat pump.

Colt-Caloris - Local Heat Pump

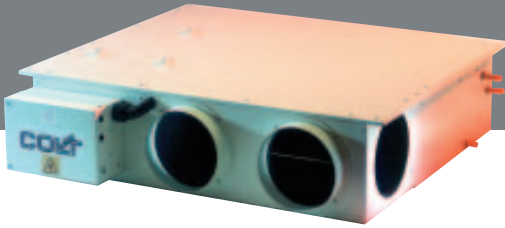

A COLT-CALORIS LOCAL HEAT PUMP

Each internal space or room contains its own local unit, installed horizontally within the ceiling void.

Units can be operated in such a way that units on the warmer part of the building cool, and transfer the thermal energy to units on the cooler side of the building. No other system has provided individual users with this level of control and flexibility without making modifications and concessions to the main system.

The operation of this unit is based on a reverse cycle heat pump within the individual unit. The heat pump includes a refrigerant circuit with both refrigerant to air and refrigerant to water heat exchangers.

A reversing valve enables each heat exchanger to act as either an evaporator or a condenser.

A small charge of refrigerant circulates only within each unit, unlike other systems which pump refrigerant throughout the whole building.

In the unlikely event of one unit failing, all the other units will carry on working independently, making the Colt-Caloris system extremely reliable.

A remote room controller sets the personal temperature, air speed and desired mode, heating, cooling or recirculate.

page 7.

FULL COMPRESSOR ENCLOSURE

Reducing noise levels is crucial for any type of air conditioning system. Colt has focused on the design and manufacture of the compressor housing within the local heat pump unit. The result is the quietest running water source heat pump unit available today, thanks to its unique noise suppression system.

The compressor is suspended on twin sets of anti-vibration mounts. Both mounts are further suspended onto the housing which is also sealed and insulated away from the rest of the unit.

During the development of the product, any additional noise provided by the integral horizontal compressor has been successfully absorbed, to within approximately 0.5dB to 1.0 dB sound power level contribution, using very effective noise attenuation.

The fan decks are state of the art and help make the Colt-Caloris, Europe's quietest water source heat pump system.



Please contact Colt International Ltd for further information on our range of vertical wall units.



Colt-Caloris - Central Heat Pump



B CENTRAL HEAT PUMP

Colt has worked with Daikin, renowned the world over as leaders in air conditioning systems, to produce a specially designed central heat pump unit which works in conjunction with the Colt-Caloris system.

The purpose of the central external heat pump is to maintain the optimum temperature in the water loop between 15 °C and 30 °C, but since the building's mass helps to maintain the water loop temperature, this heat pump is rarely in operation.

The central heat pump will remain on stand-by for approximately 85% of the year.

UNIT TECHNICAL DATA

The Colt/Daikin central heat pump units are available from 5 hp up to 90 hp depending on the size of the system.

Unit sizes and technical data are available on request from Colt International Ltd.



OPERATION IN SUMMER

During the summer months, the central heat pump operates like a chiller unit but with greater efficiency, dissipating heat. Most water chiller systems operate around 5 °C to 14 °C whereas the Colt-Caloris system only starts up when the temperature exceeds 28 °C to 30 °C.

It is much easier to cool water at 28 °C than it is at 6 °C. As a result the heat pump works at a higher efficiency for less time during the day. As soon as the water temperature reaches the normal specified level, the unit stops and waits until the water becomes excessively warm again, thus saving energy.

OPERATION IN WINTER

In winter, most internal rooms will require warm air. The local heat pumps take the heat energy out of the water loop which finally causes a heat deficiency within the system. The system copes with this by taking the cold external air and cooling it further, then transferring this heat energy into the loop.

Colt/Daikin specially modified central heat pump

Colt-Caloris - Neutral Water Loop

C NEUTRAL WATER LOOP

The whole basis behind the Colt-Caloris system is to circulate water around the building between the local units and the central heat pumps at 15 °C to 30 °C thus minimising losses whilst saving energy.

All the local units and external mounted heat pumps are connected by a main two pipe, water loop system.

With the temperature of the water being neutral, insulated piping and traditional copper piping are not needed. Plastic polyethylene piping can be used offering many cost and reliability benefits.

The pipes can be quickly installed into the system without any risk of condensation.

- No refrigerant circulating through the building
- Simple, non-specialist pipe installation
- Easily modified or extended

POLYETHYLENE PIPING

Piping for the water loop is made from smooth polyethylene, with an expected life span of over 50 years.

Piping is tested to BS 7291 and listed in the WRAS (Water Regulations Advisory Scheme) and is BBA Approved.

Polyethylene piping has many exceptional physical properties including:

Resistance to stress crack formation

Long term stress rupture resistance at high temperatures

Kink resistance

Exceptional thermal ageing resistance

Chemical resistance and completely non-corroding

ADDITIONAL OPTIONS FOR CONTROLLING THE WATER LOOP

On refurbishment projects, a heat injection source, such as a boiler system, may already be installed within the building. Similarly, a heat rejection source, such as a chiller unit or evaporative cooling tower may also be installed. If this is the case, then a central heat pump is not required and the system can be reconfigured to make use of existing systems.

Ground coupled (long term) storage systems can be very beneficial and can even be capable of solely serving the water loop all year round depending on local geothermal situations.

Please contact Colt for further information.

It's so quiet, the only way to know it's on is by feeling the air

Thermal Energy



Modern heat pumps reduce CO₂ emissions

Energy can be taken from the warmer South side of the building and re-used on the North side

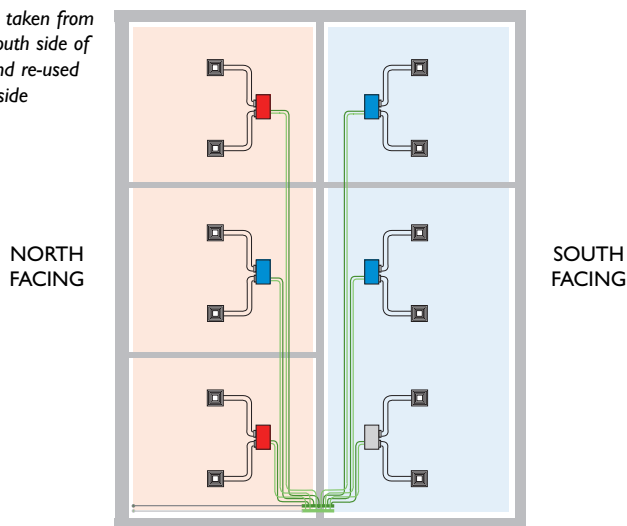

THERMAL ENERGY

The ideal scenario is for the water loop to utilise the building's thermal mass as an additional energy store. Pipes can be laid into the building's concrete structure, taking advantage of the free thermal energy, which in turn can be stored and re-used later in the day.

Reducing energy consumption and the impact industry has on the environment has always played an important strategic part in the philosophy of Colt.

The Colt-Caloris system contains lower quantity of refrigerants compared to any other air conditioning systems, yet the key feature is the energy efficiency due to the neutral water loop system.

Local loop heat injection is achieved by utilising 'wasted' heat coming from kitchens, hotel rooms, plant rooms, offices, IT rooms or collectively from South facing rooms.

Local loop heat rejection may be achieved by the re-use of energy from units in the heating mode, for example, those found on the North facing side of the building.

Colt-Caloris is a totally unique 'sustainable' and safe system.

We would recommend that the Colt-Caloris system be used for this project

Foremans
Building Services Consultants

Extract taken from a detailed report prepared by Foremans regarding a project in Watford

People work better in Colt Conditions

HOTELS, HOSPITALS, SCHOOLS & OFFICES

Many of today's modern buildings contain air conditioning to improve the internal climate of the building.

While natural ventilation and external solar shading are starting to play a major part in the building design process, there can also be a need to provide air conditioning.

This is especially the case in buildings with large glass façades without openable windows, where internal heat loads are high.

Centralised air handling plant with large ducted systems are becoming less popular due to the space required and the operational and installation costs.

Increasingly, hygiene problems have arisen, making these systems even less desirable.

Colt-Caloris is the ideal solution for hotels, hospitals, schools and offices with its reduced installation costs, greater efficiency over conventional systems, low noise levels and safe, environmentally friendly operation.

Colt-Caloris - the way forward

The external central heat pump installed at Nic. Oud Direct Mail, Holland



Ziengs Shoes, based in Assen, Holland

Over 65 Colt-Caloris units ranging from sizes 2 to 4 were installed into this new office development



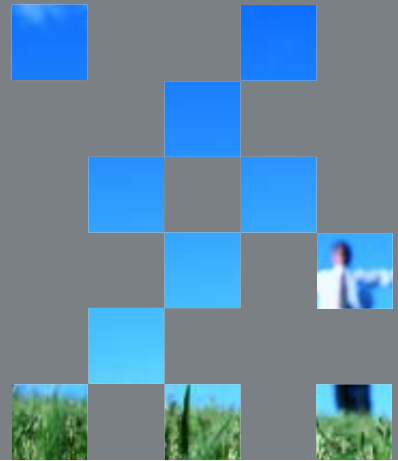

*Princess Alexandra Hospital,
Harlow, Essex*

*Working with main contractor, Charter
Construction Plc, Colt-Caloris was
installed to provide better internal
conditions to the new day unit*



*A new office development in Holland
comprising three separate buildings,
each one containing a complete
Colt-Caloris system*



Zon, Holland

*A newly constructed auction house
for fruit and vegetables with offices
at the front of the complex.
Colt-Caloris is installed within these
offices spanning three floors*

Specification

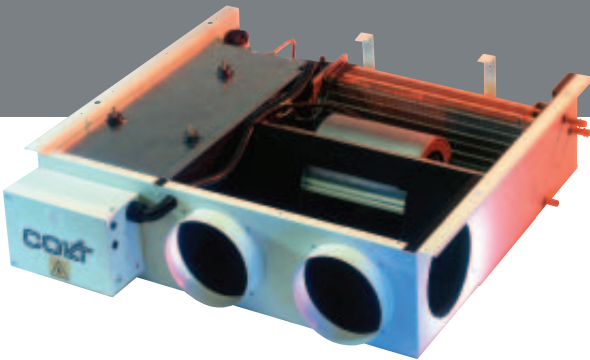

Description - The System

The air conditioning system shall be Colt-Caloris Reverse Cycle Water Source Heat Pumps manufactured by Colt Group Limited, New Lane, Havant, Hampshire, PO9 2LY.

The system shall be capable of providing the relevant duties scheduled whilst operating with a water loop temperature between 15 °C to 30 °C with an optimum efficiency being achieved between 20 °C to 25 °C.

The water loop temperature shall be maintained via centrally positioned reverse cycle water source heat pumps.

There shall be no limit to the number of room units that can be incorporated into the system.

The water loop energy transfer system shall use uninsulated plastic pipe supplied and installed by the services contractor.

The system shall comply with PED 97/23/EC.

A Local Unit

The local Colt-Caloris unit shall be completely self contained and capable of achieving a NR level of 28 / 30 / 32 / 34.

The local Colt-Caloris unit shall not exceed a depth of 247mm.

Each unit shall comprise a thermal and acoustic lined galvanised steel chassis up to 2mm thick, enclosing the following items:

Double inlet centrifugal type recirculating air fan / fans, directly coupled to a 3 speed electric motor of the permanent split capacitor type with sealed for life bearings and thermal overload protection built in as standard.

Balanced fan / motor assembly is secured through anti-vibration mounts to the fan deck.

Air to refrigerant heat exchanger (air coil) constructed from 32-row (8 x 4) grooved copper tubes with mechanically bonded aluminium fins and expansion through the capillary.

Water to refrigerant heat exchanger (water coil) constructed from copper with special finned and grooved spiral shell-in-tube to refrigerant heat exchanger.

Horizontal rotary type refrigerant compressor supported on anti-vibration mountings designed to minimise vibration.

Air filters shall be easily accessible, washable and long life. Filter Grade EU3.

The unit shall be supplied complete with an integral acoustically lined discharge plenum and 200mm spigots.

Thermal and acoustic insulation up to 20mm thickness throughout shall be fire rated Class 'O' foam.

Each unit shall have inbuilt protection controls including HP cut out and LP cut out, low limit water thermostat / automatic reset frost thermostat and thermal current overload protection on the compressor and fan motor.

Each unit shall be supplied with 15mm plain copper tails suitable for compression fitting to the water loop by the installation contractor. The contractor shall provide suitable fittings and isolating valves on the water inlet and outlet and a flow setting /regulating device on the return pipe.

Each unit is designed to be self purging. The contractor shall arrange for venting of air from the water system pipework.

Each unit shall be suitable for 220 240V/1/50Hz and shall include an integral start delay timer built into the unit.

Each unit is supplied with an electrical noise EMC filter and full width insulated, hygienic stainless steel drainage tray.

The unit shall be energy efficient with an overall cooling Coefficient of Performance of between 4.11 and 5.55 or greater, supported by independent test data according to EN 255.

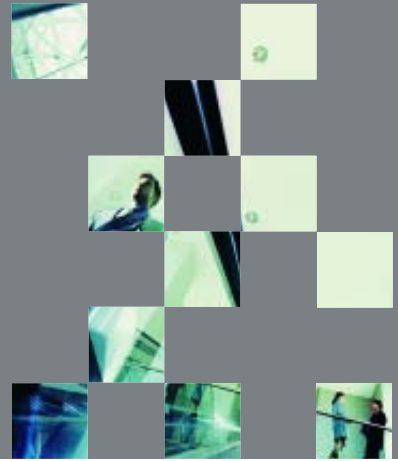

All units are extensively checked for zero defects

B Central Heat Pump

A specially designed, low noise, centralised heat pump must be used to maintain the overall system parameters.

The central heat pump must be suitable for maintaining the water loop temperature between 15 °C and 30 °C throughout peak summer and winter periods and include a hydronic module to reduce installation time.

The central heat pump must be optimised for use with R-407C.

The central heat pump shall include a suitably sized water pump and expansion vessel with the possibility for a buffer tank.

The central heat pump must also include frost protection, pressure regulating valve, pressure port pump, filter, safety valve, manometer, drain valve, fill valve, air purge, evaporator, flow switch, pressure port evaporator, water temperature sensor in and water temperature sensor out.

Shut off valves for easy water filter cleaning must also be provided.

Please contact Colt for full technical selection and performance data.

C Water Loop

The system shall utilise long life polyethylene piping for the neutral water loop system with an expected life expectancy in excess of 50 years.

Piping shall comply with BS 7291 and must be BBA Approved made under ISO 9001 quality procedures and listed in the WRAS (Water Regulations Advisory Scheme).

Minimum pressure rating shall be no less than 6 Bar pressure with a resistance of up to 45 Bar.

Piping shall be at least 1.9mm thick with an overall diameter of at least 20mm.

Controls

Analogue or digital controls shall be provided for climate control of the individual space.

Each unit shall be capable of operating independently using manual controls or, in a master / slave group scheme of up to six units in conjunction with a digital controller.

Each controller shall incorporate an on-off switch / fan speed selector and temperature control adjustment, mode switch, unit functioning and fault LED indicators. It shall also include an optional comprehensive diagnostic facility, which can be accessed to determine the status of the unit and be fitted with a controller designed to maintain the temperature selected by controlling the compressor to operate in either cooling or heating modes as required.

Manufacture

All Colt-Caloris units will be manufactured in accordance with BS EN ISO9001:1994, and will be sound tested to EN 3741, and will be capacity tested to EN 255.

CalorisNet - BMS

As part of the complete package, Colt can offer an advanced Building Management System called CalorisNet. Please contact Colt for further information



Technical Data - Dimensions & Options

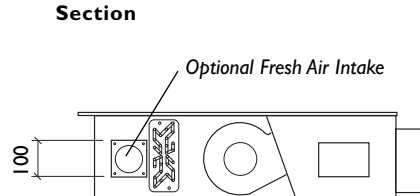
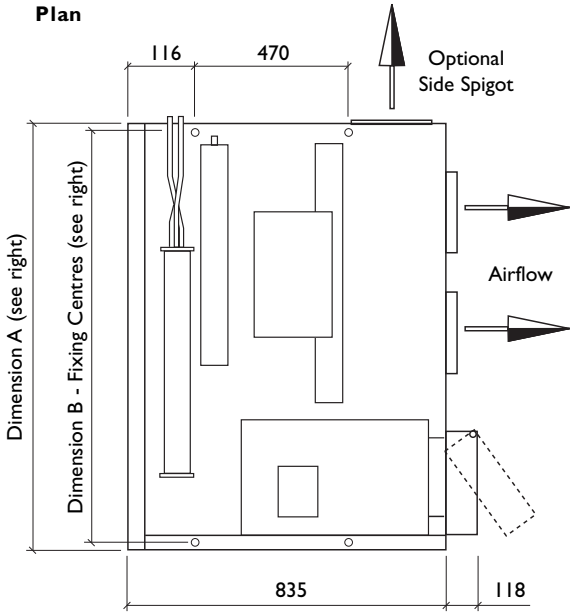
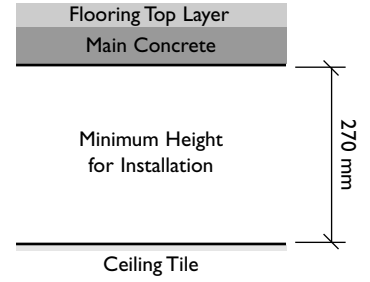

Water Connections

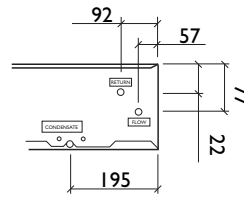

15mm Diameter Copper Tails
Outlet - (Return)
Inlet - (Flow)

15mm Diameter Stainless Steel
Drain - (Condensate)

Unit Size Options

Left Handed

Right Handed (Size 1 only)

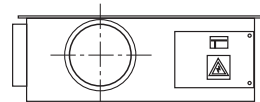
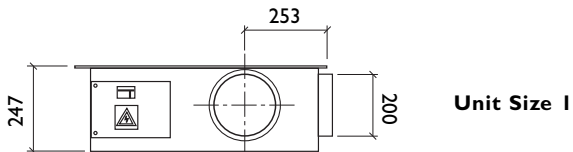

Standard Spigot diameter is 200mm

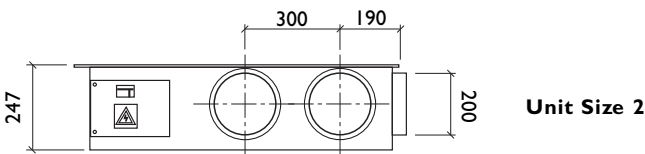

250mm diameter Spigots are also available on request

A condensate pump is also optional.

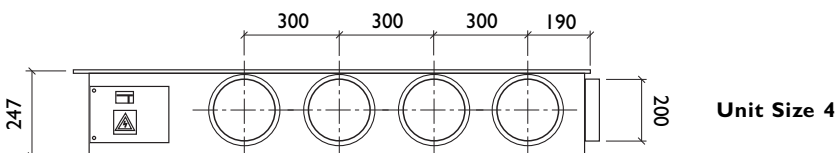
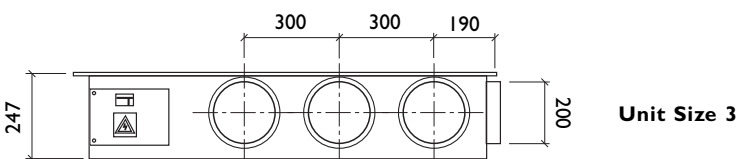

Technical Data - Performance

	Size 1	Size 2	Size 3	Size 4
--	--------	--------	--------	--------

Cooling Performance @ 25 °C, RH 50%, Water 20/26 °C

	Size 1	Size 2	Size 3	Size 4
Cooling Capacity	1508 W	2230 W	3360 W	4770 W
Compressor Power Input	316 W	442 W	572 W	871 W
COP Compressor Input Only	4.77	5.05	6.40	5.48
Unit COP (according to EN 255-2)	4.11	4.21	5.55	4.72

	Size 1	Size 2	Size 3	Size 4
--	--------	--------	--------	--------

Heating Performance @ 20 °C, Water 20/15 °C

	Size 1	Size 2	Size 3	Size 4
Heating Capacity	1510 W	2350 W	3370 W	4135 W
Compressor Power Input	374 W	543 W	696 W	948 W
COP Compressor Input Only	4.04	4.33	4.84	4.36
Unit COP (according to EN 255-2)	3.55	3.72	4.29	3.80

Air Side Heat Exchanger

Model / Type	3/8 Curved Cu - tube with shaped aluminium fins			
Air Qty (Sleep) m ³ /h (l/s)	216 (60)	390 (108)	420 (117)	- - -
Air Qty (Standard) m ³ /h (l/s)	266 (74)	460 (128)	720 (200)	940 (261)
Air Qty (Turbo) m ³ /h (l/s)	342 (95)	520 (144)	940 (261)	1260 (350)
Standard Static Pressure	30 Pa	30 Pa	30 Pa	30 Pa
Maximum Static Pressure	50 Pa	50 Pa	50 Pa	70 Pa

Water Side Heat Exchanger

Model / Type	Finned and Grooved Spiral Shell-in-tube			
Water Connections	15mm	15mm	15mm	15mm
Water - Nominal Flow l/s (l/min)	0.074 (4.5)	0.106 (6.4)	0.133 (8.0)	0.178 (10.7)
Waterside - Differential Pressure	1.3 kPa	1.5 kPa	2.0 kPa	8.0 kPa
Waterside - Max Pressure	10 bar	10 bar	10 bar	10 bar
Water Capacity	2.4 L	2.4 L	2.8 L	3.3 L

Noise Data (Cooling mode at standard power)

	Size 1	Size 2	Size 3	Size 4
Sound Power (SWL)	47 dB (A)	49 dB (A)	50 dB (A)	51.5 dB (A)
Typical Lp	31-36 dB (A)	34-38 dB (A)	34-38 dB (A)	35-38 dB (A)
Typical NR	25 - 30	28 - 32	29 - 32	28 - 31

Heat Pump

Compressor Type	Low Noise	Cradle	Hermetic	Horizontal Rotary
CFC - Free Refrigerant	R134a	R407C	R410A	R410A
Refrigerant Quantity	0.395 kg	0.82 kg	1.10 kg	1.40 kg

Dimensions & Weights

	Dim A	Dim B	Unit Weight	Spigot Options
Unit Size 1	820	776	72 kg	1,2
Unit Size 2	980	936	80 kg	1,2,3
Unit Size 3	1280	1236	88 kg	1,2,3,4
Unit Size 4	1580	1536	108 kg	1,2,3,4,5

Electrical Data

	Size 1	Size 2	Size 3	Size 4
Power Supply (V / ph / Hz)	230/1/50	230/1/50	230/1/50	230/1/50
Total Absorbed Power @ 30°C	0.5 kW	0.7 kW	0.8 kW	1.2 kW
Nominal Current Compressor/Fan	1.9 / 0.25 A	2.8 / 0.4 A	3.4 / 0.5 A	5.0 / 0.5 A
Max Starting Current	16 A	16 A	16 A	19 A
Minimum External/Internal Fuse	10 A	10 A	10 A	10 A
Max No. Units off 13 Amp Supply	4	3	2	2

Digital controls only

Acoustical data are based on the report of Peutz & Associ s BV (NL) and SRL Limited (UK) in accordance with EN ISO 3741:1999, EN ISO 5135:1999, BS 4856:1997 and Eurovent 8/2 1992. Sound power levels are based on measurements taken in a reverberation chamber with a half second echo and 8-4 kg/m² ceiling mass.

Performance data has been measured in a EN 255-certified laboratory.

Cooling correction tables

Entering Dry Bulb Temp °C		Entering Wet Bulb Temp (% RH)	Caloris Entering Water Temperatures °C			
			15	20	25	30
		15	Total CAP 0.92	0.87	0.82	0.78
			kW comp 0.84	0.93	1.01	1.11
			COP 1.09	0.94	0.81	0.70
19	(66)		Sens. Heat C 0.77	0.73	0.67	0.63
21	(53)		Sens. Heat C 0.92	0.88	0.82	0.78
23	(42)		Sens. Heat C 1.09	1.04	0.99	0.94
25	(33)		Sens. Heat C 1.21	1.16	1.12	1.06
		17	Total CAP 1.03	0.96	0.88	0.82
			kW comp 0.88	0.98	1.06	1.17
			COP 1.17	0.98	0.83	0.70
21	(67)		Sens. Heat C 0.81	0.76	0.71	0.66
23	(55)		Sens. Heat C 0.96	0.91	0.86	0.80
25	(45)		Sens. Heat C 1.12	1.07	1.02	0.97
27	(36)		Sens. Heat C 1.25	1.19	1.14	1.09
		18	Total CAP 1.07	1.00	0.93	0.87
			kW comp 0.90	1.00	1.09	1.20
			COP 1.19	1.00	0.86	0.73
23	(62)		Sens. Heat C 0.89	0.84	0.79	0.74
25	(51)		Sens. Heat C 1.05	1.00	0.95	0.90
27	(40)		Sens. Heat C 1.19	1.14	1.09	1.03
		19	Total CAP 1.11	1.04	0.99	0.93
			kW comp 0.91	1.02	1.10	1.21
			COP 1.21	1.02	0.90	0.77
23	(70)		Sens. Heat C 0.83	0.78	0.73	0.68
25	(57)		Sens. Heat C 0.98	0.93	0.87	0.82
27	(48)		Sens. Heat C 1.14	1.09	1.03	0.98
29	(39)		Sens. Heat C 1.26	1.21	1.16	1.10
		21	Total CAP 1.17	1.10	1.03	0.98
			kW comp 0.95	1.08	1.17	1.32
			COP 1.22	1.01	0.88	0.74
25	(70)		Sens. Heat C 0.84	0.79	0.75	0.69
27	(59)		Sens. Heat C 1.00	0.95	0.89	0.84
29	(49)		Sens. Heat C 1.17	1.11	1.05	0.99

Total CAP - Total Gross Unit Cooling Capacity
COP - Coefficient Of Performance

kW comp - Compressor Absorbed Power input
Sens Heat C - Sensible Heat Capacity

Example

1. Select your actual Entering Dry and Wet Bulb air inlet conditions in the table (rows)
2. Search for the nominal loop water inlet temperature (columns)
3. You will find your multiplier for the real Total Capacity, the compressor absorbed power, COP and Sensible Heat Capacity

Selection is wanted at Air on 23 °C and 55 % R.H. This is 17 °C EWB and the project design in summer is at Water On 25 °C:

Your Multipliers :

Total Cooling Capacity:	0.88
Compressor absorbed input power:	1.06
COP:	0.83
Sensible Heat Capacity:	0.86

Use standard specification of the systems to arrive at the final performance values eg:

for Caloris size 2:

Total Cooling Capacity:	= 0.88 x 2230 = 1962 W
Compressor absorbed input power:	= 1.06 x 442 = 469 W
COP:	= 0.83 x 5.05 = 4.19

Heating correction tables

Entering Dry Bulb Temp °C	Caloris Entering Water Temperatures °C											
	12 HCAP	12 COP	17 HCAP	17 COP	20 HCAP	20 COP	23 HCAP	23 COP	25 HCAP	25 COP	28 HCAP	28 COP
18	0.86	0.96	0.96	1.01	1.02	1.05	1.07	1.08	1.12	1.11	1.17	1.15
20	0.85	0.92	0.94	0.97	1.00	1.00	1.05	1.03	1.10	1.06	1.16	1.10
21	0.84	0.90	0.93	0.94	0.99	0.98	1.04	1.01	1.09	1.04	1.15	1.08
22	0.83	0.88	0.93	0.92	0.98	0.95	1.03	0.99	1.08	1.02	1.14	1.04
24	0.81	0.83	0.90	0.88	0.96	0.91	1.01	0.94	1.06	0.97	1.12	1.00

HCAP - Heating Capacity

COP - Coefficient Of Performance

Procedure

1. Select the design Entering Dry Bulb air inlet conditions in the table (rows)
2. Find the nominal loop Water Inlet Temperature (columns)
3. You will find your multiplier for the Total Capacity and COP ratios.

Example

Design allows for Air Entering Dry Bulb Air Temperature at 22 °C.
and Water Inlet Temperature at 25 °C:

Your Multipliers: Heating Capacity: 1.08
COP: 1.02

Use standard specification of the systems to arrive at the final performance values:

e.g. for Caloris size 2: Heating Capacity: = 1.08 x 2350 = 2538 W
COP: = 1.02 x 4.33 = 4.42

OPERATING RANGE

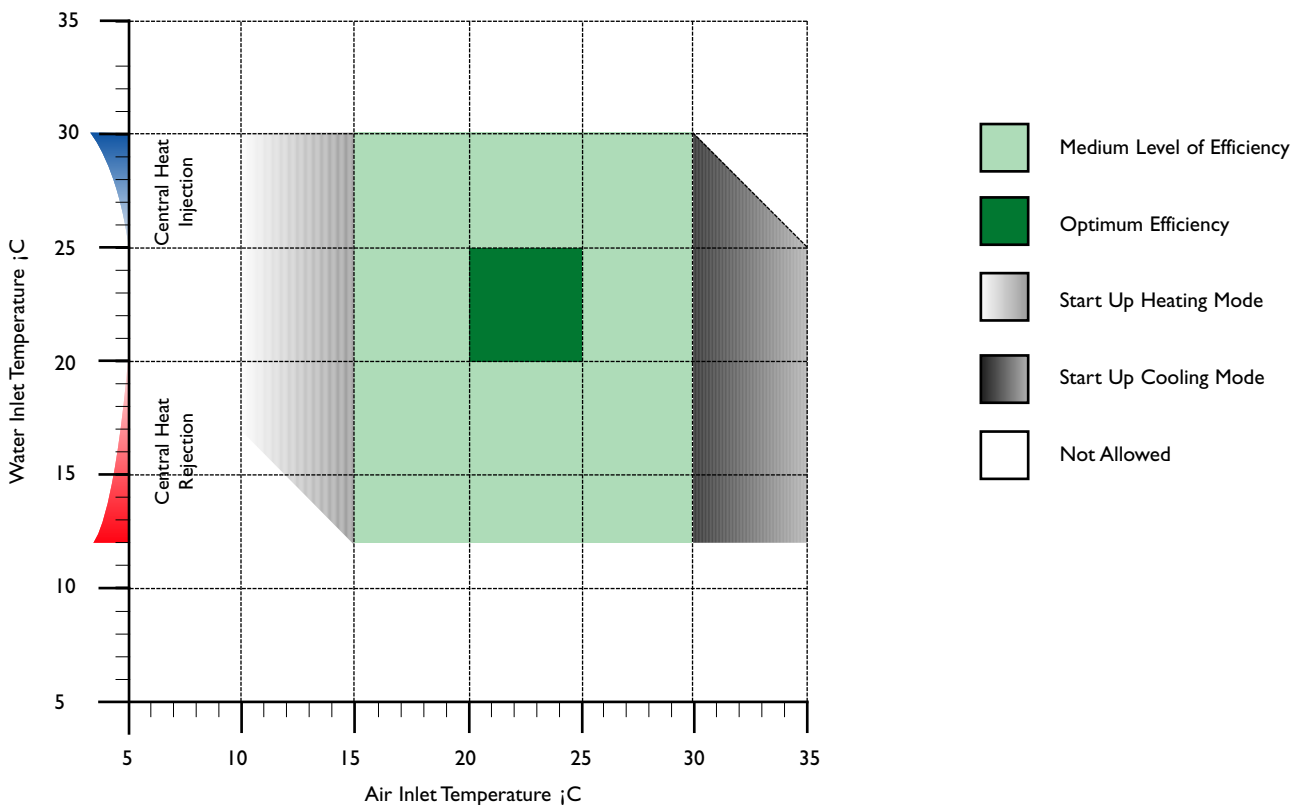



TESTING

Colt has tested all models extensively in its in-house Sound Cells and in addition, commissioned independent testing by the Laboratory of Acoustics Peutz & Associés BV. Duty tests have also been undertaken by BSRIA and TNO.

Fan, heating and cooling duties have been tested to EN 255 Standard and Eurovent conditions by independently certified laboratories.

The Colt-Caloris has been tested to the following Standards:

EN ISO 3741:1999 Acoustics - Determination of sound power levels of noise sources using sound pressure - precision methods for reverberation chambers.

EN ISO 5135:1999 Acoustics - Determination of sound power levels of noise from air-terminal devices, air-terminal units, dampers and valves by measurement in a reverberation chamber.

BS 4856:1997 Methods for Testing and rating fan coil units, unit heaters and unit coolers. Part 4: Determination of sound power levels of fan coil units, unit heaters and unit coolers using reverberation chambers.

EUROVENT 8/2-1992 Acoustical Measurements of fan coil units in reverberation chamber.

EN ISO 255-2 Air Conditioners, liquid chilling packages and heat pumps with electrically driven compressors, testing and requirements for making space heating units.

COLT SERVICE

Part of the Colt Group of companies, Colt Service offers a comprehensive range of maintenance packages incorporating the maintenance and repair of all building services equipment including non Colt products.

Colt Service provide a 24 hour, 365 day emergency cover as standard.

MAINTENANCE

Colt-Caloris units require very little maintenance. A simple service once a year is sufficient.

The air filter may be periodically cleaned with a vacuum cleaner or by washing at any time, but it must be dry before re-installation.

All components are sealed for life, e.g. motor bearings and compressor parts which contain non-user serviceable parts. Therefore, if in the unlikely event that any component develops a fault, it will need to be completely replaced by a suitable service contractor.

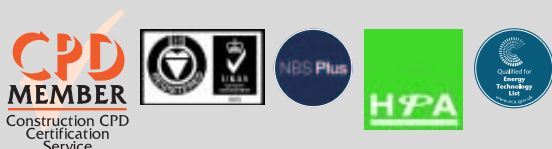

Architectural Solutions

Climate Control

Smoke Control

Service and Maintenance

Colt International Limited

New Lane Havant

Hampshire PO9 2LY

Tel +44(0)23 9245 1111

Fax +44(0)23 9245 4220

info@coltgroup.com

www.coltgroup.com